



UNIVERSITY OF CAMBRIDGE INTERNATIONAL EXAMINATIONS
General Certificate of Education
Advanced Subsidiary Level and Advanced Level

PHYSICS

9702/33

Paper 31 Advanced Practical Skills 1

October/November 2009

CONFIDENTIAL INSTRUCTIONS



Great care should be taken to ensure that any confidential information given does not reach the candidates either directly or indirectly.

No access to the Question Paper is permitted in advance of the examination.

If you have any problems or queries regarding these Instructions, please contact CIE
by e-mail: international@cie.org.uk,
by phone: +44 1223 553554,
by fax: +44 1223 553558,
stating the Centre number, the nature of the query and the syllabus number quoted above.

This document consists of **7** printed pages and **1** blank page.



Preparing apparatus

These instructions detail the apparatus required for the experiments in the Question Paper. It is essential that absolute confidentiality is maintained in advance of the examination: the contents of these instructions must not be revealed either directly or indirectly to candidates.

No access is permitted to the Question Paper in advance of the examination.

If you have problems or queries regarding these instructions, please contact CIE:

by e-mail: international@cie.org.uk,
or by telephone: +44 1223 553554,
or by fax: +44 1223 553558,

stating the nature of the query and quoting the syllabus and paper numbers (9702/33).

It is assumed that the ordinary apparatus of a Physics laboratory will be available.

Number of sets of apparatus

The number of sets of apparatus provided for each experiment should be $\frac{1}{2}N$, where N is the number of candidates taking the examination. There should, in addition, be a few spare sets of apparatus available in case problems arise during the examination.

Organisation of the examination

Candidates should be allowed access to the apparatus for each experiment for one hour only. After spending one hour on one experiment, candidates should change over to the other experiment. The order in which a candidate attempts the two experiments is immaterial.

Assistance to Candidates

Candidates should be informed that, if they find themselves in real difficulty, they may ask the Supervisor for practical assistance, but that the extent of this assistance will be reported to the Examiner, who may make a deduction of marks.

Assistance should only be given:

when it is asked for by a candidate,
or as directed in the Notes sections of these instructions,
or where apparatus is seen to have developed a fault.

Assistance should be restricted to enabling candidates to make observations and measurements. Observations and measurements must not be made for candidates, and no help should be given with data analysis or evaluation.

All assistance given to candidates must be reported on the Supervisor's Report Form.

Faulty apparatus

In cases of faulty apparatus (not arising from a candidate's mishandling) that prevent the required measurements being taken, the Supervisor may allow extra time to give the candidate a fair opportunity to perform the experiment as if the fault had not been present. The candidate should use a spare copy of the Question Paper when the fault has been rectified or when working with a second set of apparatus.

Supervisor's Report

The Supervisor should complete the Supervisor's Report Form on pages 7 and 8 and enclose it in the envelope containing the answers of the candidates. If more than one envelope is used, a copy of the report must be enclosed in each envelope.

Question 1**Apparatus requirements (per set of apparatus unless otherwise specified)**

Two identical expendable springs (e.g. Philip Harris catalogue reference B8A41397). The springs should have an external diameter of approximately 15 mm, with a coiled length of approximately 20 mm, and a spring constant of approximately 25 N m^{-1} .

40 cm length of thin string. See Note 1.

Mass hanger. This should itself have a mass of 100 g and this mass should be clearly marked, in kilograms, on the hanger.

Seven 50 g slotted masses.

Metre rule with a millimetre scale.

30 cm rule with a millimetre scale.

Protractor.

Two retort stands and four bosses. See Note 2.

Two nails about 50 mm long. See Note 2.

Set square.

Metal rod of diameter 10 mm and at least 40 cm long (the rod from a retort stand is suitable). See Note 2.

Card on which information about the springs is written:

- the spring constant k in newtons per metre, written as " $k = \dots \text{ N m}^{-1}$ ".
- the unloaded length of the coiled section in metres, written as "unloaded length of coiled section of spring A = $\dots \text{ m}$ ".
- the mass of the mass hanger in kilograms, written as "mass of mass hanger = $\dots \text{ kg}$ ".

Notes

- 1 Tie a spring onto each end of the string and then tie a loop in the centre, as shown in Fig. 1.1.
- 2 Assemble the apparatus as shown in Fig. 1.1.

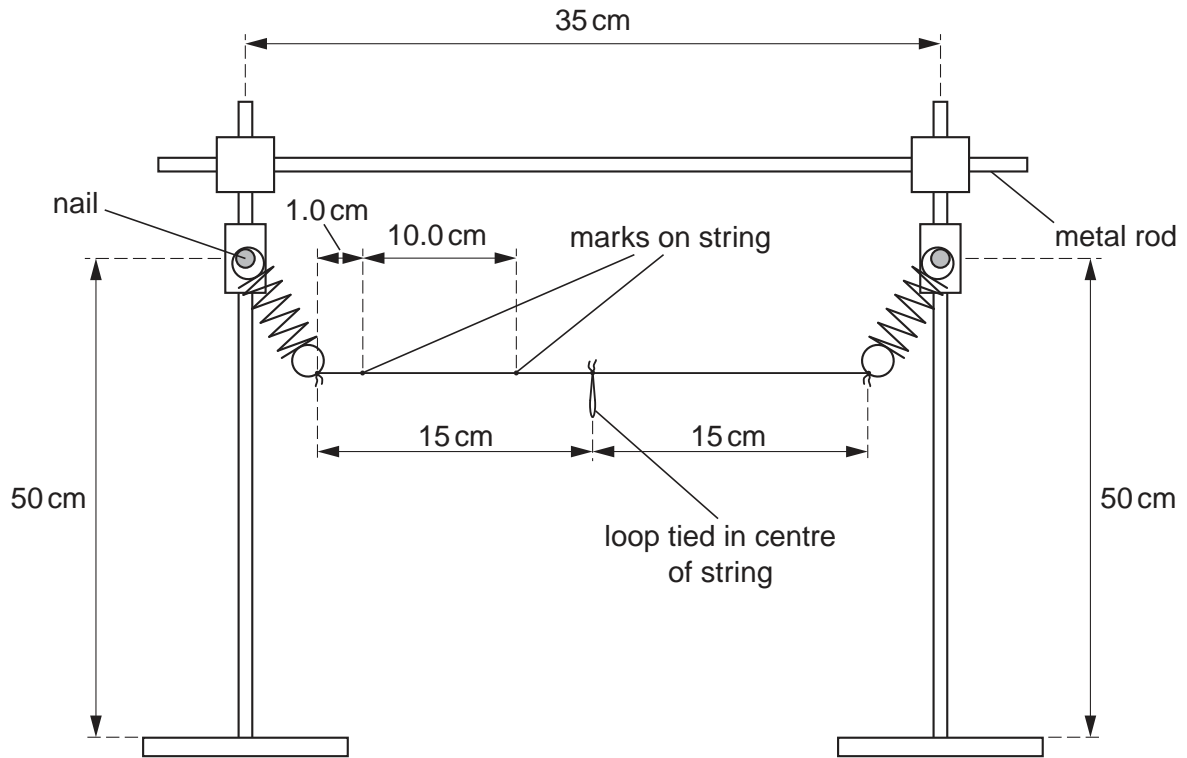

Fig. 1.1

Make two small, clear marks on the string in the positions shown in Fig. 1.1. (One way of doing this is to use a small dab of correction fluid).

- 3 If the apparatus is to be used by a second candidate then it should be restored to its original state.

Information required by Examiners

A sample set of numerical results, clearly labelled "Supervisor's Results".

Question 2**Apparatus requirements (per set of apparatus unless otherwise specified)**

Cylindrical hardwood rod of diameter approximately 25 mm and length approximately 15 cm (a section of broom handle is suitable). The surface should be dry and unvarnished, and rubbed with sandpaper to ensure that it is clean and smooth.

Retort stand, boss and clamp.

Mass hanger. The mass hanger should itself have a mass of 50 g.

Selection of slotted masses. The masses supplied should allow the candidate to add masses to the hanger in 10 g increments, up to 250 g. For example, four 50 g, two 20 g and one 10 g masses would be suitable.

Two 100 g masses which will also fit the hanger.

A mass of approximately 10 g (a small nut and bolt with some washers, or similar). It should be labelled "10 g". See Note 1.

A 70 cm length of nylon monofilament thread of diameter about 0.2 mm (fishing line is suitable). See Note 1.

Stopwatch reading to 0.1 s or better.

Manual vernier calipers (not digital). See Note 2.

Metre rule with a millimetre scale.

Notes

- 1 Tie one end of the thread to the 10 g mass. Tie a small loop at the other end of the thread to fit the hook of the mass hanger.
- 2 If there are insufficient vernier calipers for candidates to have one set each, then each set of vernier calipers may be shared between up to three candidates.
- 3 If the apparatus is to be used by a second candidate then it should be restored to its original state.

Information required by Examiners

A sample set of numerical results, clearly labelled "Supervisor's Results".

BLANK PAGE

Permission to reproduce items where third-party owned material protected by copyright is included has been sought and cleared where possible. Every reasonable effort has been made by the publisher (UCLES) to trace copyright holders, but if any items requiring clearance have unwittingly been included, the publisher will be pleased to make amends at the earliest possible opportunity.

University of Cambridge International Examinations is part of the Cambridge Assessment Group. Cambridge Assessment is the brand name of University of Cambridge Local Examinations Syndicate (UCLES), which is itself a department of the University of Cambridge.

9702/33/CI/O/N/09

This form should be completed and sent to the Examiner with the scripts.

SUPERVISOR'S REPORT FORM

General Certificate of Education Advanced Subsidiary Level and Advanced Level

October/November Session 2009

The Supervisor's Report should give full details of:

- (a) any help given to a candidate (including the nature of the help given and the name and candidate number of the candidate);
- (b) any cases of faulty apparatus (including the nature of the problem, the action taken to rectify it, any additional time allowed, and the name and candidate number of the candidate);
- (c) any accidents that occurred during the examination;
- (d) any other difficulties experienced by candidates, or any other information that is likely to assist the Examiner, especially if this information cannot be discovered in the scripts.

Cases of individual hardship, such as illness, bereavement or disability, should be reported direct to CIE on the normal Special Consideration form.

Information required by Examiners

Question 1: Sample set of results, clearly labelled "Supervisor's Results".

Question 2: Sample set of results, clearly labelled "Supervisor's Results".

Supervisor's Report



Supervisor's Report (continued)

Declaration

(to be signed by the Supervisor)

The preparation of this practical examination has been carried out so as to maintain fully the security of the examination.

Signed

Name

Centre Number

Name of Centre

